

125YTB & 250YTB BRONZE SERIES THREADED Y STRAINERS

Pressures To 400 PSIG (27.6 barg)
Temperatures to 406°F (207°C)

- One piece cast body
- Upper and lower machined seats
- Generous screen area and properly proportioned straining chamber minimize initial pressure drop while maximizing time between cleanings
- Drain/Blow-off connection furnished with plug

RATINGS

Ends ASME/ANSI	Pressure PSIG (barg)	Temperature °F (°C)
WSP		
B16.15 Class 125 NPT	125 (8.6)	@ 406 (207)
B16.15 Class 250 NPT	250 (17.2)	@ 406 (207)
WOG		
B16.15 Class 125 NPT	200 (13.8)	@ 150 (66)
B16.15 Class 250 NPT	400 (27.6)	@ 150 (66)

OPTIONS

- Other perforated screens and mesh liners

ORDERING CODE

SIZING INFO

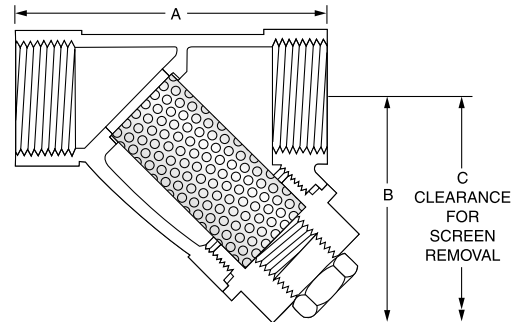
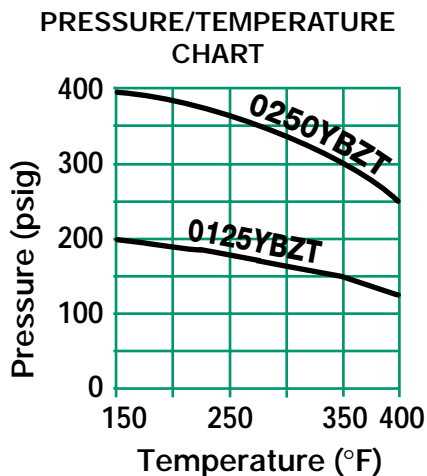

Connections: 3/8" – 3" NPT

SCREEN OPENINGS

SIZE	STANDARD SCREEN	MATERIALS
1/4" – 2"	20 mesh	304 SS
2 1/2" – 3"	3/64 Perf.	304 SS

DIMENSIONS inches (mm) AND WEIGHTS pounds (kg)

SIZE	A		B		C		D		WEIGHT	
	125 lb.	250 lb.	125 lb.	250 lb.	125 lb.	250 lb.	125 lb.	250 lb.	125 lb.	250 lb.
3/8 (10)	3 1/4 (82)	—	2 1/2 (65)	—	3 1/2 (89)	—	3/8 (10)	—	1 (0.45)	—
1/2 (15)	3 1/4 (82)	3 1/8 (78)	2 1/2 (65)	2 1/4 (57)	3 1/2 (89)	3 3/8 (99)	3/8 (10)	3/8 (10)	1 (0.45)	1.25 (0.57)
3/4 (20)	4 (100)	3 3/8 (90)	2 3/4 (70)	2 1/2 (64)	4 1/2 (114)	4 3/8 (106)	3/8 (10)	3/8 (10)	1 (0.45)	1.50 (0.68)
1 (25)	4 1/2 (115)	4 3/8 (106)	3 (75)	3 3/8 (81)	5 (127)	4 7/8 (124)	1/2 (15)	3/4 (20)	2 (0.91)	2 (0.91)
1-1/4 (32)	5 3/8 (136)	5 1/8 (129)	3 1/2 (90)	3 3/8 (92)	5 3/4 (146)	5 3/4 (146)	1/2 (15)	3/4 (20)	2 (0.91)	3 (1.36)
1-1/2 (40)	6 1/4 (158)	5 15/16 (151)	3 3/4 (98)	4 3/8 (106)	6 3/8 (162)	6 3/8 (168)	1/2 (15)	3/4 (20)	3 (1.36)	4 (1.81)
2 (50)	7 1/2 (191)	7 3/4 (197)	5 1/2 (138)	5 3/4 (146)	9 1/8 (230)	8 3/8 (208)	1/2 (15)	3/4 (20)	7 (3.18)	7.50 (3.40)
2-1/2 (65)	9 1/8 (230)	—	6 (150)	—	10 (254)	—	1/2 (15)	—	9.75 (4.42)	—
3 (80)	10 1/4 (260)	—	6 1/4 (160)	—	10 3/8 (264)	—	1/2 (15)	—	13 (5.90)	—

(1) Teflon is limited to 400°F maximum sustained operating temperature. For higher temperatures, consult factory.