



**FIGURE 800 SAFETY RELIEF VALVE**

# FIGURE 800 SERIES

**SIZES ½" – 1½"**

**PRESSURES to 900 PSIG at 422°F**

- Meets ASME VIII Code for Liquid, Steam, Air & Gas Service
- "UV" National Board Certified
- Short Blowdown
- No Ring Adjustments Required
- Unitized Bonnet Design
- All SS Internals/SS Springs
- Pivoting Disc Design
- Full Nozzle
- Soft Seat Design Available
- Wide Variety of Options

## APPLICATION DATA

- Liquid Filled Pressure Vessels & Systems
- Steam/air/gas Pressure Vessels & Systems
- Low temperature cryogenic systems
- Pumps, Tanks & Hydraulic Systems
- Pressure Reducing Stations
- Vacuum Systems
- OEM Equipment

## APPLICABLE CODES

- ASME Section VIII "UV" for Liquid/Steam/Air/Gas
- API 527
- Canadian Registration # OG0591.9C

Sizing Guidelines

Testing Specifications

Installation/Maintenance

## OPTIONS

- Screwed, Plain & Packed Caps
- BSP Connections
- Oxygen Cleaning
- EPDM, Viton & TFE/25% Glass Soft Seats
- Low Temperature Cryogenic Service Trim\*

## MODELS

- 810 - Bronze Bonnet & Base, SS Disc
- 812 - EPDM Seat on 810
- 814 - Viton Seat on 810
- 816 - TFE/25% Glass Seat on 810
- 820 - Bronze Bonnet, SS Base & Disc
- 822 - EPDM Seat on 820
- 824 - Viton Seat on 820
- 826 - TFE/25% Glass Seat on 820
- 860 - 316 SS Bonnet, Base & Disc
- 862 - EPDM Seat on 860
- 864 - Viton Seat on 860
- 866 - Teflon Seat on 860

## VALVE RATINGS *Capacity Charts*

Model	Temperature* °F (°C)	Pressure PSIG (bar)		
		D,E Orifices	F,G Orifices	H Orifice
810/812	-20-406 (-28.9-207.8)	5-250 (0.34-17.24)		
814/816	-20-400 (-28.9-204.4)	5-250 (0.34-17.24)		
820 <sup>(1)</sup>	-20-422 (-28.9-216.7)	5-900 (0.34-62.06)	5-600 (0.34-41.37)	5-500 (0.34-34.48)
822 <sup>(1)</sup> /824 <sup>(2)</sup> /826 <sup>(2)</sup>	-20-400 (-28.9-204.4)			
860	-20-800 (-28.9-427)			
862/864/866	-20-400 (-28.9-204.4)			

Maximum Backpressure (Plain/Packed Cap) - 50 PSIG (3.45 barg)  
 Vacuum Pressure Range - 10 to 30" HG (3.38.64 to 1015.92 mbarg)

<sup>(1)</sup> Maximum pressure for steam is 300 PSIG (20.67 barg).

<sup>(2)</sup> Maximum pressure for steam is 250 PSIG (17.4 barg).



\*For temperatures to -400°F (-240°C), consult factory.

# FIGURE 800 SERIES

## SPECIFICATION

The valve shall meet the ASME Section VIII code for liquid, steam, air and gas services. It shall be "UV" National Board Certified. It shall have non-adjustable blowdown that shall be less than 10% for steam, air or gas and less than 20% for liquid. The valve shall consist of a unitized bonnet design guaranteeing proper guiding and making the valve extremely dependable in terms of pop action, seat tightness and repeatability. The disc shall have a pivoting design which optimizes the seating performance. The valve shall have a full nozzle for optimum flow performance. Internal trim (excepting the base) shall be stainless steel.

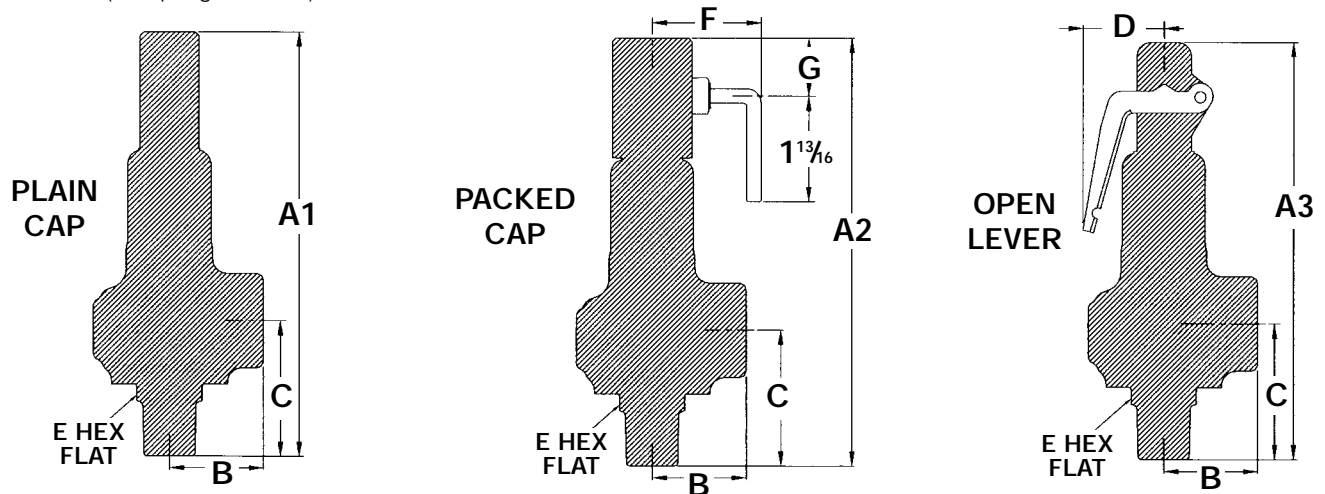

**DIMENSIONS\*** inches (mm) **AND WEIGHTS** pounds (kg)

Model	Inlet	Orifice	Outlet	A1	A2	A3	B	C	D <sup>(1)</sup>	E	F	G	Weight
8**+DCA	½ (15)	D	1 (25)	7⅞ (18.73)	7⅞ (18.73)	7⅞ (18.10)	1⅜ (3.49)	2¼ (5.72)	1⅜ <sub>32</sub> (3.57)	1⅜ (2.86)	1⅜ <sub>16</sub> (4.92)	½ (1.27)	2.50 (1.13)
8**+EDA	¾ (20)	E	1¼ (32)	8⅞ (22.54)	8⅞ (22.54)	8⅞ (22.23)	1⅝ (4.13)	2⅝ <sub>16</sub> (5.87)	1⅜ <sub>32</sub> (3.57)	1¼ (3.18)	1⅜ <sub>16</sub> (4.92)	1⅜ (2.70)	4.50 (2.04)
8**+FEA	1 (25)	F	1½ (40)	9⅞ (25.08)	9⅞ (25.08)	9⅞ (24.77)	1⅞ (4.76)	2⅜ <sub>16</sub> (7.14)	2¼ (5.72)	1½ (3.81)	1⅜ <sub>16</sub> (4.92)	1⅜ (2.70)	7.00 (3.18)
8**+GFA	1¼ (32)	G	2 (50)	12 (30.48)	12 (30.48)	11⅞ (30.16)	2⅝ (5.40)	3 (7.62)	2¼ (5.72)	1⅜ (4.76)	2⅝ (5.40)	1⅜ (4.45)	11.50 (5.22)
8**+HGA	1½ (40)	H	2½ (65)	13⅞ (33.97)	13⅞ (33.97)	13¼ (33.66)	2⅞ <sub>16</sub> (6.51)	3½ (8.89)	3 (7.62)	2½ (6.35)	2⅝ (5.40)	1⅜ (4.45)	17.00 (7.71)

\*Accurate to ±1/8". \*\*Use appropriate model number. <sup>(1)</sup> Add 50% to D Dimension when lever is pulled out to manually operate valve.  
+Use appropriate Cap Letter

### ORDERING CODE

MODEL NUMBER (Must be 3 Digits)	CAP	ORIFICE	INLET SIZE	CONNECTIONS	—	SERVICE	SET PRESSURE (Must be 3 Digits)
example: 810	N	D	C	A	—	A	025
810 - Bronze Bonnet & Base, SS Disc	N - Plain Cap	D	C - ½	A - MPT x FTP	—	A - Air/Gas Sect. VIII	Set Pressure
812 - EPDM Seat on 810	E - Open Lever	E	D - ¾	F - MBSP x FBSP	—	M - Steam Non-code	LAS - Loosely Assembled†
814 - Viton Seat on 810	P - Packed Cap	F	E - 1	Z - Other	—	N - Air/Gas Non-code	
816 - TFE/25% Glass Seat on 810		G	F - 1¼		—	P - Liquid Non-code	
820 - Bronze Bonnet, SS Base & Disc		H	G - 1½		—	T - Steam Sect. VIII	
822 - EPDM Seat on 820					—	V - Vacuum	
824 - Viton Seat on 820					—	W - Liquid Sect. VIII	
826 - TFE/25% Glass Seat on 820					—	G - Loosely Asm. Gas†	
860 - 316 SS Bonnet, Base & Disc					—	X - Loosely Asm. Liquid†	
862 - EPDM Seat on 860					—	Z - Other	
864 - Viton Seat on 860					—		
866 - Teflon Seat on 860					—		

†Spence Certified Assemblers Only

# FIGURE 800 SERIES

## MATERIALS OF CONSTRUCTION

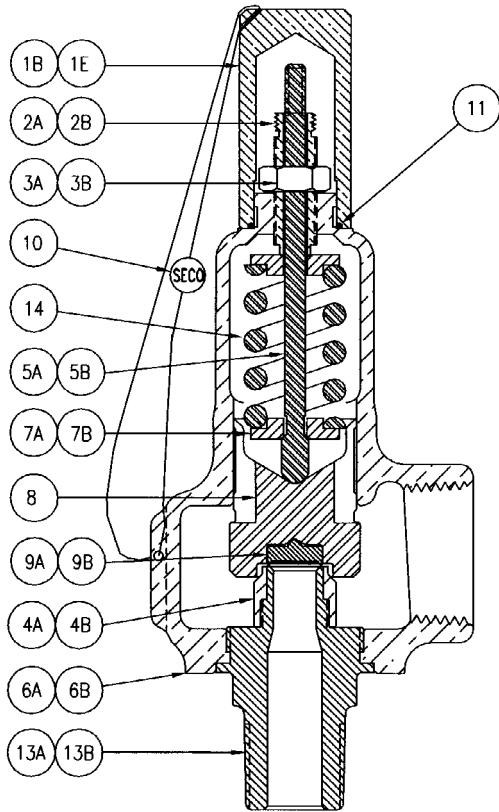

**PLAIN CAP VALVE**

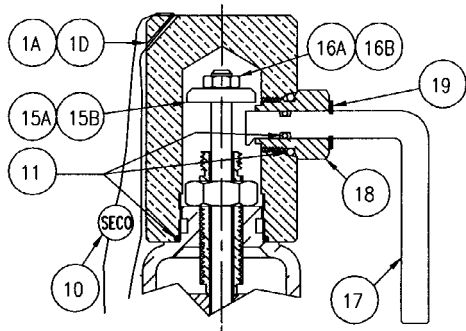

**PACKED CAP OPTION**

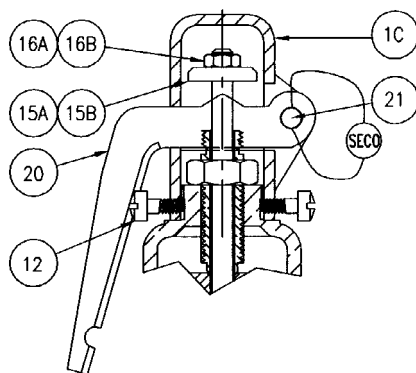

**OPEN LEVER OPTION**

Materials		
Ref	Part Name	Material
1A	Cap - Packed	Brass ASTM B16
1B	Cap - Plain	Brass ASTM B16
1C	Cap - Open Lever	Zinc Alloy
1D	Cap - Packed (860 Series)	316 SST ASTM A276
1E	Cap - Plain (860 Series)	316 SST ASTM A276
2A	Adjusting Bolt	Brass ASTM B16
2B	Adjusting Bolt (860 Series)	316 SST ASTM A276
3A	Adjusting Bolt Locknut	303 SST ASTM A582
3B	Adjusting Bolt Locknut (860 Series)	316 SST ASTM A276
4A	Base Ring (Liquid Only)	Brass ASTM B16
4B	Base Ring (Liquid Only - Series 860)	316 SST ASTM A276
5A	Spindle	304 SST ASTM A479
5B	Spindle (860 Series)	316 SST ASTM A276
6A	Bonnet	Bronze ASME SB62
6B	Bonnet	316 SST ASTM A351 CF8M
7A	Spring Washer	303 SST ASTM A582
7B	Spring Washer (860 Series)	316 SST ASTM A276
8	Disc Holder - Metal/Soft <sup>1</sup>	316 SST ASTM A351 CF8M
9A	Disc - Metal	316 SST ASTM A276
9B	Disc Assembly - Soft	316SST - EPDM/Viton/TFE
10	Seal and Wire	Lead and SST
11	O-rings, various <sup>3</sup>	Buna-N/TFE
12	Lock Screw	Plated Steel
13A	Base <sup>2</sup>	Brass/Brz, ASTM B283/ASME SB62
13B	Base <sup>2</sup> (820 & 860 Series)	316 SST ASTM A276
14	Spring	316 SST or 302 SST or 17-7 SST
15A	Spindle Nut	Steel
15B	Spindle Nut (860 Series)	316 SST ASTM A276
16A	Spindle Nut Locknut	Plated Steel
16B	Spindle Nut Locknut (860 Series)	316 SST ASTM A582
17	Lifting Lever Packed Cap	316 SST ASTM A276
18	Packed Cap Plug	316 SST ASTM A276
19	Cap Snap Ring	SST AMS 5813, S15700
20	Lifting Lever Open Cap	Plated Steel
21	Lifting Cap Pin Open Lever	Steel
22	Nameplate (Not Shown)	SST
23	Drive Screw (Not Shown)	SST

<sup>(1)</sup> ½, ¾ & 1 (15, 20, 25 mm) Metal and Soft Seat disc holders are different. 1¼ & 1½ (32 & 40mm) disc holders are identical.

<sup>(2)</sup> ½ & ¾ (15, 20 mm) Gas and Liquid bases are identical. 1, 1¼ & 1½ (25, 32 & 40 mm) Liquid Bases differ from Gas bases.

<sup>(3)</sup> TFE cap o-ring for models 816, 826, 866.

# FIGURE 800 SERIES SOFT SEATS

Safety Valves with metal seats will start to leak at 90% of set pressure. A Spence Safety Valve equipped with a soft seat seals on both the metal and soft seats (see illustration). As a result, it will not begin to leak until system pressure reaches 95% of set pressure, minimizing system energy loss.

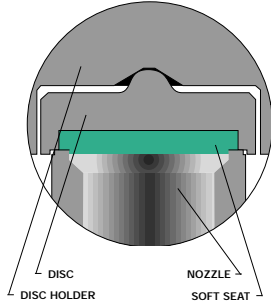

The o-rings in standard soft seat safety valves tend to blow out during discharge. Spence Soft Seat Safety Valves utilize a flat soft seat insert in the disc assembly of the valve that stays in place during operation, thus providing hassle-free operation.

There are many troublesome applications where using a Spence Soft Seat Safety Valve can reduce costly downtime and repair costs. Consider a Spence Soft Seat Safety Valve for:

- Operating very close to set pressure
- Heavy vibration
- Hard-to-hold fluids
- Occasional foreign particles
- Icing problems
- Pipe strain due to excessive discharge

## SERVICE RECOMMENDATIONS\*

### EPDM Soft Seat

**WET - -20 to 422°F (-29 to 216°C)**  
**DRY - -20 to 250°F (-29 to 121°C)**

Acetone	Freon 22
Acetylene Gas	Hydrazine
Beer	Lindol Hydraulic Fluid
Bleach Liquor	Lye
Brake Fluid	Methanol
Calcium Chloride	Methyl Alcohol
Carbon Monoxide	Methyl Butyl Ketone
Carbonic Acid	Nitrogen
Citric Acid	<b>STEAM</b>
Denatured Alcohol	Sulfur Hexafluoride
Ethylene Diamine	<b>WATER</b>

### Viton Soft Seat

**-20 to 400°F (-29 to 204°C)**

#### AIR

Benzoic Acid	Dowtherm A	Iodine
Benzul Alcohol	Ethane	Kerosene
Butane	Ethyl Alcohol	Linseed Oil
Butyl Alcohol	Ethyl Chloride	Methane
Carbon Disulfide	Ethylene	Mineral Oils
Carbon Tetrachloride	Ethylene Glycol	Natural Gas
Castor Oil	Fuel Oil	Petroleum Oil
Chlorine	Gasoline	Propane
Chromic Acid	Glucose	Propyl Alcohol
Corn Oil	Glycerin	Propylene
Crude Oil	Helium	Sulfur Dioxide
Diesel Oil	Hydraulic Oil	Turpentine
	Hydrogen Gas	

### TFE/25% Glass Soft Seat

**-400 to 400°F (-240 to 204°C)**

#### CRYOGENIC SERVICE

Helium	Nitrogen
Hydrogen	Oxygen

\*These recommendations should be used as a guide only. It is the sole responsibility of the user to select suitable materials.

# SATURATED STEAM CAPACITY CHART – MODEL 800

**ASME Section VIII “UV” 90% rated at 10% Overpressure LBS/HR (KGS/HR)**  
**Flow Coefficient = .9 x .975 = .878**

**LBS/HR**

Set Pressure PSIG	Orifice Area in <sup>2</sup>				
	D 0.1188	E 0.2116	F 0.3318	G 0.5424	H 0.8479
5 *	122	217	341	557	870
10 *	149	265	416	679	1062
15	176	313	491	802	1254
20	203	361	566	925	1445
25	229	409	641	1047	1637
30	256	456	716	1170	1829
35	286	509	798	1305	2040
40	315	562	881	1440	2251
45	345	614	963	1575	2461
50	374	667	1046	1709	2672
55	404	720	1128	1844	2883
60	434	772	1211	1979	3094
65	463	825	1293	2114	3305
70	493	877	1376	2249	3516
75	522	930	1458	2384	3727
80	552	983	1541	2519	3937
85	581	1035	1623	2654	4148
90	611	1088	1706	2789	4359
95	640	1140	1788	2923	4570
100	670	1193	1871	3058	4781
105	699	1246	1953	3193	4992
110	729	1298	2036	3328	5203
115	758	1351	2118	3463	5414
120	788	1404	2201	3598	5624
125	818	1456	2283	3733	5835
130	847	1509	2366	3868	6046
135	877	1561	2448	4003	6257
140	906	1614	2531	4137	6468
145	936	1667	2614	4272	6679
150	965	1719	2696	4407	6890
155	995	1772	2779	4542	7100
160	1024	1825	2861	4677	7311
165	1054	1877	2944	4812	7522
170	1083	1930	3026	4947	7733
175	1113	1982	3109	5082	7944
180	1143	2035	3191	5217	8155
185	1172	2088	3274	5352	8366
190	1202	2140	3356	5486	8577
195	1231	2193	3439	5621	8787
200	1261	2246	3521	5756	8998
205	1290	2298	3604	5891	9209
210	1320	2351	3686	6026	9420
215	1349	2403	3769	6161	9631
220	1379	2456	3851	6296	9842
225	1408	2509	3934	6431	10053
230	1438	2561	4016	6566	10263
235	1468	2614	4099	6700	10474
240	1497	2667	4181	6835	10685
245	1527	2719	4264	6970	10896
250	1556	2772	4346	7105	11107
255	1586	2824	4429	7240	11318
260	1615	2877	4511	7375	11529
265	1645	2930	4594	7510	11740
270	1674	2982	4676	7645	11950
275	1704	3035	4759	7780	12161
280	1733	3088	4841	7914	12372
285	1763	3140	4924	8049	12583
290	1793	3193	5007	8184	12794
295	1822	3245	5089	8319	13005
300	1852	3298	5172	8454	13216
1.0	6.0	10.5	16.5	27.0	42.2

**KGS/HR**

Set Pressure Barg	Orifice Area cm <sup>2</sup>				
	D .766	E 1.365	F 2.141	G 3.499	H 5.47
0.4*	57	102	160	261	409
0.6*	64	115	180	294	459
0.8*	71	127	199	326	509
1*	78	140	219	358	560
1.2	86	152	239	390	610
1.4	93	165	259	423	661
1.6	100	177	278	455	711
1.8	107	190	298	487	762
2	114	203	318	519	812
2.2	121	216	339	554	866
2.4	129	230	360	589	921
2.6	137	244	382	625	977
2.8	145	258	404	660	1032
3	152	271	426	696	1088
3.2	160	285	447	731	1143
3.4	168	299	469	767	1199
3.6	176	313	491	802	1254
3.8	183	327	512	838	1309
4	191	341	534	873	1365
4.2	199	354	556	909	1420
4.4	207	368	578	944	1476
4.6	215	382	599	980	1531
4.8	222	396	621	1015	1587
5	230	410	643	1051	1642
5.2	238	424	664	1086	1698
5.4	246	438	686	1122	1753
5.6	253	451	708	1157	1809
5.8	261	465	729	1192	1864
6	269	479	751	1228	1920
6.2	277	493	773	1263	1975
6.4	284	507	795	1299	2031
6.6	292	521	816	1334	2086
7	308	548	860	1405	2197
7.5	327	583	914	1494	2336
8	347	617	968	1583	2474
8.5	366	652	1022	1671	2613
9	386	687	1077	1760	2752
9.5	405	721	1131	1849	2890
10	424	756	1185	1938	3029
10.5	444	790	1240	2026	3168
11	463	825	1294	2115	3306
11.5	483	860	1348	2204	3445
12	502	894	1402	2292	3584
12.5	522	929	1457	2381	3722
13	541	964	1511	2470	3861
13.5	560	998	1565	2559	4000
14	580	1033	1619	2647	4138
14.5	599	1067	1674	2736	4277
15	619	1102	1728	2825	4416
15.5	638	1137	1782	2913	4554
16	658	1171	1836	3002	4693
16.5	677	1206	1891	3091	4832
17	696	1240	1945	3179	4970
17.5	716	1275	1999	3268	5109
18	735	1310	2053	3357	5248
18.5	755	1344	2108	3446	5386
19	774	1379	2162	3534	5525
19.5	794	1413	2216	3623	5664
20	813	1448	2271	3712	5802
20.5	832	1483	2325	3800	5941
0.1	3.9	6.9	10.9	17.7	27.7

\* Pressure settings below 15 PSIG (1.034 barg) are non code.



# AIR CAPACITY CHART – MODEL 800

## ASME Section VIII “UV”

**90% rated at 10% Overpressure SCFM at 60°F \*\***

**Flow Coefficient = .9 x .975 = .878**

### SCFM

Set Pressure PSIG	Orifice Area in <sup>2</sup>				
	D 0.1188	E 0.2116	F 0.3318	G 0.5424	H 0.8479
5 *	43	77	121	198	310
10 *	53	94	148	242	378
15	63	111	175	285	446
20	72	128	201	329	514
25	82	145	228	373	583
30	91	162	255	416	651
35	102	181	284	464	726
40	112	200	313	512	801
45	123	219	343	560	876
50	133	237	372	608	951
55	144	256	402	656	1026
60	154	275	431	704	1101
65	165	294	460	753	1176
70	175	312	490	801	1251
75	186	331	519	849	1326
80	196	350	548	897	1402
85	207	368	578	945	1477
90	217	387	607	993	1552
95	228	406	637	1041	1627
100	238	425	666	1089	1702
105	249	443	695	1137	1777
110	259	462	725	1185	1852
115	270	481	754	1233	1927
120	280	500	783	1281	2002
125	291	518	813	1329	2077
130	302	537	842	1377	2152
135	312	556	872	1425	2227
140	323	575	901	1473	2302
145	333	593	930	1521	2377
150	344	612	960	1569	2452
155	354	631	989	1617	2527
160	365	649	1018	1665	2602
165	375	668	1048	1713	2677
170	386	687	1077	1761	2752
175	396	706	1106	1809	2827
180	407	724	1136	1857	2902
185	417	743	1165	1905	2977
190	428	762	1195	1953	3052
195	438	781	1224	2001	3127
200	449	799	1253	2049	3202
205	459	818	1283	2097	3277
210	470	837	1312	2145	3352
215	480	855	1341	2193	3427
220	491	874	1371	2241	3502
225	501	893	1400	2289	3577
230	512	912	1430	2337	3652
235	522	930	1459	2385	3727
240	533	949	1488	2433	3802
245	543	968	1518	2481	3877
250	554	987	1547	2529	3952
255	564	1005	1576	2577	4027
260	575	1024	1606	2625	4102
265	585	1043	1635	2673	4177
270	596	1062	1665	2721	4252
275	606	1080	1694	2769	4327
280	617	1099	1723	2817	4402
285	628	1118	1753	2865	4477
290	638	1136	1782	2913	4552
295	649	1155	1811	2961	4627
300	659	1174	1841	3009	4702
1.0	2.2	3.6	6.0	9.6	15.0

Set Pressure PSIG	Orifice Area in <sup>2</sup>				
	D 0.1188	E 0.2116	F 0.3318	G 0.5424	H 0.8479
305	670	1099	1723	2817	4404
310	680	1116	1750	2861	4472
315	691	1133	1777	2904	4540
320	701	1249	1958	3201	5004
325	712	1268	1988	3249	5079
330	722	1286	2017	3297	5154
335	733	1305	2046	3345	5229
340	743	1324	2076	3393	5304
345	754	1342	2105	3441	5380
350	764	1361	2134	3489	5455
355	775	1380	2164	3537	5530
360	785	1399	2193	3585	5605
365	796	1417	2223	3633	5680
370	806	1436	2252	3681	5755
375	817	1455	2281	3729	5830
380	827	1474	2311	3777	5905
385	838	1492	2340	3825	5980
390	848	1511	2369	3873	6055
395	859	1530	2399	3921	6130
400	869	1549	2428	3969	6205
405	880	1567	2458	4017	6280
410	890	1586	2487	4065	6355
415	901	1605	2516	4113	6430
420	911	1623	2546	4161	6505
425	922	1642	2575	4209	6580
430	933	1661	2604	4257	6655
435	943	1680	2634	4305	6730
440	954	1698	2663	4354	6805
445	964	1717	2693	4402	6880
450	975	1736	2722	4450	6955
455	985	1755	2751	4498	7030
460	996	1773	2781	4546	7105
465	1006	1792	2810	4594	7180
470	1017	1811	2839	4642	7255
475	1027	1829	2869	4690	7330
480	1038	1848	2898	4738	7405
485	1048	1867	2927	4786	7480
490	1059	1886	2957	4834	7555
495	1069	1904	2986	4882	7630
500	1080	1923	3016	4930	7705
505	1090	1942	3045	4978	-
510	1101	1961	3074	5026	-
515	1111	1979	3104	5074	-
520	1122	1998	3133	5122	-
525	1132	2017	3162	5170	-
530	1143	2036	3192	5218	-
535	1153	2054	3221	5266	-
540	1164	2073	3251	5314	-
545	1174	2092	3280	5362	-
550	1185	2110	3309	5410	-
555	1195	2129	3339	5458	-
560	1206	2148	3368	5506	-
565	1216	2167	3397	5554	-
570	1227	2185	3427	5602	-
575	1237	2204	3456	5650	-
580	1248	2223	3486	5698	-
585	1259	2242	3515	5746	-
590	1269	2260	3544	5794	-
595	1280	2279	3574	5842	-
600	1290	2298	3603	5890	-
1.0	2.2	3.6	6.0	9.6	15.0

Set Pressure PSIG	Orifice Area in <sup>2</sup>	
	D 0.1188	E 0.2116
605	1301	2121
610	1311	2138
615	1322	2155
620	1332	2373
625	1343	2391
630	1353	2410
635	1364	2429
640	1374	2448
645	1385	2466
650	1395	2485
655	1406	2504
660	1416	2523
665	1427	2541
670	1437	2560
675	1448	2579
680	1458	2597
685	1469	2616
690	1479	2635
695	1490	2654
700	1500	2672
705	1511	2691
710	1521	2710
715	1532	2729
720	1542	2747
725	1553	2766
730	1563	2785
735	1574	2804
740	1585	2822
745	1595	2841
750	1606	2860
755	1616	2878
760	1627	2897
765	1637	2916
770	1648	2935
775	1658	2953
780	1669	2972
785	1679	2991
790	1690	3010
795	1700	3028
800	1711	3047
805	1721	3066
810	1732	3084
815	1742	3103
820	1753	3122
825	1763	3141
830	1774	3159
835	1784	3178
840	1795	3197
845	1805	3216
850	1816	3234
855	1826	3253
860	1837	3272
865	1847	3291
870	1858	3309
875	1868	3328
880	1879	3347
885	1889	3365
890	1900	3384
895	1911	3403
900	1921	3422
1.0	2.2	3.6

\* Pressure settings below 15 PSIG (1.034 barg) are non code.

\*\*For other temperatures, please use temperature correction factor.



# AIR CAPACITY CHART – MODEL 800 – CONT'D.

## ASME Section VIII "UV"

90% rated at 10% Overpressure NM<sup>3</sup>/HR at 15.68°C\*\*

Flow Coefficient = .9 x .975 = .878

NM<sup>3</sup>/HR

Set Pressure Barg	Orifice Area cm <sup>2</sup>				
	D .766	E 1.365	F 2.141	G 3.499	H 5.47
0.4*	76	136	213	349	545
0.6*	86	153	240	392	612
0.8*	95	170	266	435	679
1*	105	186	292	478	747
1.2	114	203	318	521	814
1.4	123	220	345	564	881
1.6	133	237	371	607	948
1.8	142	253	397	650	1016
2	152	270	424	693	1083
2.2	162	288	452	738	1154
2.4	172	307	481	786	1228
2.6	182	325	510	833	1302
2.8	193	343	539	880	1376
3	203	362	568	928	1450
3.2	214	380	596	975	1524
3.4	224	399	625	1022	1598
3.6	234	417	654	1070	1672
3.8	245	436	683	1117	1746
4	255	454	712	1164	1820
4.2	265	473	741	1212	1894
4.4	276	491	770	1259	1968
4.6	286	510	799	1306	2042
4.8	296	528	828	1354	2116
5	307	547	857	1401	2190
5.2	317	565	886	1448	2264
5.4	328	583	915	1496	2338
5.6	338	602	944	1543	2412
5.8	348	620	973	1590	2486
6	359	639	1002	1637	2560
6.2	369	657	1031	1685	2634
6.4	379	676	1060	1732	2708
6.6	390	694	1088	1779	2782
6.8	400	713	1117	1827	2856
7	410	731	1146	1874	2930
7.2	421	750	1175	1921	3004
7.4	431	768	1204	1969	3077
7.6	442	786	1233	2016	3151
7.8	452	805	1262	2063	3225
8	462	823	1291	2111	3299
8.2	473	842	1320	2158	3373
8.4	483	860	1349	2205	3447
8.6	493	879	1378	2253	3521
8.8	504	897	1407	2300	3595
9	514	916	1436	2347	3669
9.2	524	934	1465	2394	3743
9.4	535	953	1494	2442	3817
9.6	545	971	1523	2489	3891
9.8	556	990	1552	2536	3965
10	566	1008	1581	2584	4039
10.2	576	1026	1609	2631	4113
10.4	587	1045	1638	2678	4187
10.6	597	1063	1667	2726	4261
10.8	607	1082	1696	2773	4335
11	618	1100	1725	2820	4409
11.2	628	1119	1754	2868	4483
11.4	638	1137	1783	2915	4557
11.6	649	1156	1812	2962	4631
11.8	659	1174	1841	3010	4705
12	670	1193	1870	3057	4779
12.2	680	1211	1899	3104	4853
0.1	5.2	9.2	14.6	23.6	37

Set Pressure Barg	Orifice Area cm <sup>2</sup>				
	D .766	E 1.365	F 2.141	G 3.499	H 5.47
12.4	690	1229	1928	3151	4927
12.6	701	1248	1957	3199	5001
12.8	711	1266	1986	3246	5074
13	721	1285	2015	3293	5148
13.5	747	1331	2087	3412	5333
14	773	1377	2159	3530	5518
14.5	799	1423	2232	3648	5703
15	825	1469	2304	3767	5888
15.5	851	1516	2376	3885	6073
16	877	1562	2449	4003	6258
16.5	903	1608	2521	4121	6443
17	929	1654	2594	4240	6628
17.5	955	1700	2666	4358	6813
18	980	1746	2738	4476	6998
18.5	1006	1792	2811	4595	7182
19	1032	1839	2883	4713	7367
19.5	1058	1885	2955	4831	7552
20	1084	1931	3028	4949	7737
20.5	1110	1977	3100	5068	7922
21	1136	2023	3172	5186	8107
21.5	1162	2069	3245	5304	8292
22	1188	2115	3317	5423	8477
22.5	1214	2162	3389	5541	8662
23	1240	2208	3462	5659	8847
23.5	1265	2254	3534	5777	9031
24	1291	2300	3607	5896	9216
24.5	1317	2346	3679	6014	9401
25	1343	2392	3751	6132	9586
25.5	1369	2438	3824	6251	9771
26	1395	2485	3896	6369	9956
26.5	1421	2531	3968	6487	10141
27	1447	2577	4041	6605	10326
27.5	1473	2623	4113	6724	10511
28	1499	2669	4185	6842	10696
28.5	1524	2715	4258	6960	10881
29	1550	2761	4330	7079	11065
29.5	1576	2808	4402	7197	11250
30	1602	2854	4475	7315	11435
30.5	1628	2900	4547	7433	11620
31	1654	2946	4620	7552	11805
31.5	1680	2992	4692	7670	11990
32	1706	3038	4764	7788	12175
32.5	1732	3084	4837	7907	12360
33	1758	3131	4909	8025	12545
33.5	1784	3177	4981	8143	12730
34	1809	3223	5054	8261	12915
34.5	1835	3269	5126	8380	13099
35	1861	3315	5198	8498	—
35.5	1887	3361	5271	8616	—
36	1913	3408	5343	8735	—
36.5	1939	3454	5416	8853	—
37	1965	3500	5488	8971	—
37.5	1991	3546	5560	9089	—
38	2017	3592	5633	9208	—
38.5	2043	3638	5705	9326	—
39	2069	3684	5777	9444	—
39.5	2094	3731	5850	9563	—
40	2120	3777	5922	9681	—
40.5	2146	3823	5994	9799	—
41	2172	3869	6067	9917	—
0.1	5.2	9.2	14.6	23.6	37

Set Pressure Barg	Orifice Area cm <sup>2</sup>	
	D .766	E 1.365
41.5	2198	3915
42	2224	3961
42.5	2250	4007
43	2276	4054
43.5	2302	4100
44	2328	4146
44.5	2354	4192
45	2379	4238
45.5	2405	4284
46	2431	4330
46.5	2457	4377
47	2483	4423
47.5	2509	4469
48	2535	4515
48.5	2561	4561
49	2587	4607
49.5	2613	4653
50	2639	4700
50.5	2664	4746
51	2690	4792
51.5	2716	4838
52	2742	4884
52.5	2768	4930
53	2794	4976
53.5	2820	5023
54	2846	5069
54.5	2872	5115
55	2898	5161
55.5	2923	5207
56	2949	5253
56.5	2975	5299
57	3001	5346
57.5	3027	5392
58	3053	5438
58.5	3079	5484
59	3105	5530
59.5	3131	5576
60	3157	5622
60.5	3183	5669
61	3208	5715
61.5	3234	5761
62	3260	5807
0.1	5.2	9.2

\* Pressure settings below 15 PSIG (1.034 barg) are non code.

\*\*For other temperatures, please use temperature correction factor.



# WATER CAPACITY CHART – MODEL 800

**ASME Section VIII “UV”**  
**90% rated at 10% Overpressure GPM at 60°F\*\***  
**Flow Coefficient = .9 x .836 = .752**

## GPM

Set Pressure PSIG	Orifice Area in <sup>2</sup>				
	D 0.1188	E 0.2116	F 0.3318	G 0.5424	H 0.8479
5 *	9.6	17.1	26.8	43.9	68.6
10 *	12.3	21.8	34.2	55.9	87.4
15	14.4	25.7	40.3	65.8	102.9
20	16.3	29.0	45.5	74.4	116.3
25	18.0	32.0	50.2	82.1	128.3
30	19.5	34.8	54.5	89.1	139.3
35	21.1	37.6	58.9	96.3	150.5
40	22.5	40.1	63.0	102.9	160.9
45	23.9	42.6	66.8	109.2	170.6
50	25.2	44.9	70.4	115.1	179.9
55	26.4	47.1	73.8	120.7	188.7
60	27.6	49.2	77.1	126.0	197.0
65	28.7	51.2	80.3	131.2	205.1
70	29.8	53.1	83.3	136.1	212.8
75	30.9	55.0	86.2	140.9	220.3
80	31.9	56.8	89.0	145.5	227.5
85	32.9	58.5	91.8	150.0	234.5
90	33.8	60.2	94.4	154.4	241.3
95	34.7	61.9	97.0	158.6	247.9
100	35.6	63.5	99.5	162.7	254.4
105	36.5	65.1	102.0	166.7	260.7
110	37.4	66.6	104.4	170.7	266.8
115	38.2	68.1	106.7	174.5	272.8
120	39.0	69.5	109.0	178.3	278.7
125	39.8	71.0	111.3	181.9	284.4
130	40.6	72.4	113.5	185.5	290.0
135	41.4	73.8	115.7	189.1	295.6
140	42.2	75.1	117.8	192.5	301.0
145	42.9	76.4	119.9	195.9	306.3
150	43.7	77.7	121.9	199.3	311.6
155	44.4	79.0	123.9	202.6	316.7
160	45.1	80.3	125.9	205.8	321.8
165	45.8	81.5	127.9	209.0	326.8
170	46.5	82.8	129.8	212.2	331.7
175	47.1	84.0	131.7	215.3	336.5
180	47.8	85.2	133.6	218.3	341.3
185	48.5	86.3	135.4	221.3	346.0
190	49.1	87.5	137.2	224.3	350.6
195	49.8	88.6	139.0	227.2	355.2
200	50.4	89.8	140.8	230.1	359.7
205	51.0	90.9	142.5	233.0	364.2
210	51.6	92.0	144.3	235.8	368.6
215	52.3	93.1	146.0	238.6	373.0
220	52.9	94.2	147.6	241.4	377.3
225	53.5	95.2	149.3	244.1	381.6
230	54.1	96.3	151.0	246.8	385.8
235	54.6	97.3	152.6	249.5	390.0
240	55.2	98.3	154.2	252.1	394.1
245	55.8	99.4	155.8	254.7	398.2
250	56.4	100.4	157.4	257.3	402.2
255	56.9	101.4	159.0	259.9	406.2
260	57.5	102.4	160.5	262.4	410.2
265	58.0	103.3	162.0	264.9	414.1
270	58.6	104.3	163.6	267.4	418.0
275	59.1	105.3	165.1	269.9	421.8
280	59.6	106.2	166.6	272.3	425.7
285	60.2	107.2	168.0	274.7	429.4
290	60.7	108.1	169.5	277.1	433.2
295	61.2	109.0	171.0	279.5	436.9
300	61.7	110.0	172.4	281.9	440.6
1.0	0.10	0.20	0.28	0.48	0.74

Set Pressure PSIG	Orifice Area in <sup>2</sup>				
	D 0.1188	E 0.2116	F 0.3318	G 0.5424	H 0.8479
305	62.2	110.9	173.8	284.2	444.3
310	62.8	111.8	175.3	286.5	447.9
315	63.3	112.7	176.7	288.8	451.5
320	63.8	113.6	178.1	291.1	455.0
325	64.3	114.4	179.5	293.4	458.6
330	64.7	115.3	180.8	295.6	462.1
335	65.2	116.2	182.2	297.8	465.6
340	65.7	117.1	183.6	300.1	469.1
345	66.2	117.9	184.9	302.3	472.5
350	66.7	118.8	186.2	304.4	475.9
355	67.2	119.6	187.6	306.6	479.3
360	67.6	120.4	188.9	308.8	482.7
365	68.1	121.3	190.2	310.9	486.0
370	68.6	122.1	191.5	313.0	489.3
375	69.0	122.9	192.8	315.1	492.6
380	69.5	123.8	194.0	317.2	495.9
385	69.9	124.6	195.3	319.3	499.1
390	70.4	125.4	196.6	321.4	502.4
395	70.8	126.2	197.8	323.4	505.6
400	71.3	127.0	199.1	325.5	508.8
405	71.7	127.8	200.3	327.5	511.9
410	72.2	128.5	201.6	329.5	515.1
415	72.6	129.3	202.8	331.5	518.2
420	73.0	130.1	204.0	333.5	521.3
425	73.5	130.9	205.2	335.5	524.4
430	73.9	131.6	206.4	337.4	527.5
435	74.3	132.4	207.6	339.4	530.6
440	74.8	133.2	208.8	341.3	533.6
445	75.2	133.9	210.0	343.3	536.6
450	75.6	134.7	211.2	345.2	539.6
455	76.0	135.4	212.3	347.1	542.6
460	76.4	136.2	213.5	349.0	545.6
465	76.9	136.9	214.7	350.9	548.5
470	77.3	137.6	215.8	352.8	551.5
475	77.7	138.4	217.0	354.7	554.4
480	78.1	139.1	218.1	356.5	557.3
485	78.5	139.8	219.2	358.4	560.2
490	78.9	140.5	220.4	360.2	563.1
495	79.3	141.2	221.5	362.0	566.0
500	79.7	142.0	222.6	363.9	568.8
505	80.1	142.7	223.7	365.7	-
510	80.5	143.4	224.8	367.5	-
515	80.9	144.1	225.9	369.3	-
520	81.3	144.8	227.0	371.1	-
525	81.7	145.5	228.1	372.9	-
530	82.1	146.1	229.2	374.6	-
535	82.4	146.8	230.2	376.4	-
540	82.8	147.5	231.3	378.1	-
545	83.2	148.2	232.4	379.9	-
550	83.6	148.9	233.5	381.6	-
555	84.0	149.6	234.5	383.4	-
560	84.3	150.2	235.6	385.1	-
565	84.7	150.9	236.6	386.8	-
570	85.1	151.6	237.7	388.5	-
575	85.5	152.2	238.7	390.2	-
580	85.8	152.9	239.7	391.9	-
585	86.2	153.5	240.8	393.6	-
590	86.6	154.2	241.8	395.3	-
595	86.9	154.9	242.8	396.9	-
600	87.3	155.5	243.8	398.6	-
1.0	0.10	0.20	0.28	0.48	0.74

Set Pressure PSIG	Orifice Area in <sup>2</sup>	
	D 0.1188	E 0.2116
605	87.7	156.1
610	88.0	156.8
615	88.4	157.4
620	88.7	158.1
625	89.1	158.7
630	89.5	159.3
635	89.8	160.0
640	90.2	160.6
645	90.5	161.2
650	90.9	161.8
655	91.2	162.5
660	91.6	163.1
665	91.9	163.7
670	92.3	164.3
675	92.6	164.9
680	92.9	165.5
685	93.3	166.1
690	93.6	166.8
695	94.0	167.4
700	94.3	168.0
705	94.6	168.6
710	95.0	169.2
715	95.3	169.7
720	95.6	170.3
725	96.0	170.9
730	96.3	171.5
735	96.6	172.1
740	97.0	172.7
745	97.3	173.3
750	97.6	173.9
755	97.9	174.4
760	98.3	175.0
765	98.6	175.6
770	98.9	176.2
775	99.2	176.7
780	99.5	177.3
785	99.9	177.9
790	100.2	178.4
795	100.5	179.0
800	100.8	179.6
805	101.1	180.1
810	101.4	180.7
815	101.7	181.2
820	102.1	181.8
825	102.4	182.3
830	102.7	182.9
835	103.0	183.4
840	103.3	184.0
845	103.6	184.5
850	103.9	185.1
855	104.2	185.6
860	104.5	186.2
865	104.8	186.7
870	105.1	187.2
875	105.4	187.8
880	105.7	188.3
885	106.0	188.9
890	106.3	189.4
895	106.6	189.9
900	106.9	190.4
1.0	0.10	0.20

\* Pressure settings below 15 PSIG (1.034 barg) are non code.  
 \*\*For other temperatures, please use temperature correction factor.



# WATER CAPACITY CHART – MODEL 800 – CONT'D.

**ASME Section VIII "UV"**  
**90% rated at 10% Overpressure M<sup>3</sup>/HR at 15.68°C\*\***  
**Flow Coefficient = .9 x .836 = .752**

Set Pressure Barg	Orifice Area cm <sup>2</sup>				
	D .766	E 1.365	F 2.141	G 3.499	H 5.47
0.4*	2.3	4.1	6.4	10.5	16.3
0.6*	2.6	4.7	7.4	12.1	18.8
0.8*	2.9	5.3	8.2	13.5	21
1*	3.2	5.8	9	14.7	23
1.2	3.5	6.2	9.7	15.9	24.9
1.4	3.7	6.6	10.4	17	26.6
1.6	4	7	11	18	28.2
1.8	4.2	7.4	11.6	19	29.7
2	4.4	7.8	12.2	19.9	31.2
2.2	4.6	8.1	12.8	20.9	32.6
2.4	4.8	8.5	13.3	21.8	34.1
2.6	5	8.9	13.9	22.7	35.5
2.8	5.2	9.2	14.4	23.5	36.8
3	5.3	9.5	14.9	24.4	38.1
3.2	5.5	9.8	15.4	25.2	39.4
3.4	5.7	10.1	15.9	25.9	40.6
3.6	5.8	10.4	16.3	26.7	41.7
3.8	6	10.7	16.8	27.4	42.9
4	6.2	11	17.2	28.1	44
4.2	6.3	11.3	17.6	28.8	45.1
4.4	6.5	11.5	18.1	29.5	46.1
4.6	6.6	11.8	18.5	30.2	47.2
4.8	6.8	12	18.9	30.8	48.2
5	6.9	12.3	19.2	31.5	49.2
5.2	7	12.5	19.6	32.1	50.2
5.4	7.2	12.8	20	32.7	51.1
5.6	7.3	13	20.4	33.3	52.1
5.8	7.4	13.2	20.7	33.9	53
6	7.5	13.4	21.1	34.5	53.9
6.2	7.7	13.7	21.4	35	54.8
6.4	7.8	13.9	21.8	35.6	55.7
6.6	7.9	14.1	22.1	36.2	56.5
6.8	8	14.3	22.4	36.7	57.4
7	8.2	14.5	22.8	37.2	58.2
7.2	8.3	14.7	23.1	37.8	59
7.4	8.4	14.9	23.4	38.3	59.8
7.6	8.5	15.1	23.7	38.8	60.6
7.8	8.6	15.3	24	39.3	61.4
8	8.7	15.5	24.3	39.8	62.2
8.2	8.8	15.7	24.7	40.3	63
8.4	8.9	15.9	24.9	40.8	63.8
8.6	9	16.1	25.2	41.3	64.5
8.8	9.1	16.3	25.5	41.7	65.3
9	9.2	16.5	25.8	42.2	66
9.2	9.3	16.7	26.1	42.7	66.7
9.4	9.4	16.8	26.4	43.1	67.4
9.6	9.5	17	26.7	43.6	68.2
9.8	9.6	17.2	26.9	44.1	68.9
10	9.7	17.4	27.2	44.5	69.6
10.2	9.8	17.5	27.5	44.9	70.3
10.4	9.9	17.7	27.8	45.4	70.9
10.6	10	17.9	28	45.8	71.6
10.8	10.1	18	28.3	46.2	72.3
11	10.2	18.2	28.6	46.7	73
11.2	10.3	18.4	28.8	47.1	73.6
11.4	10.4	18.5	29.1	47.5	74.3
11.6	10.5	18.7	29.3	47.9	74.9
11.8	10.6	18.9	29.6	48.3	75.6
12	10.7	19	29.8	48.7	76.2
12.2	10.8	19.2	30.1	49.2	76.8
.1	0.02	0.05	0.06	0.11	0.17

Set Pressure Barg	Orifice Area cm <sup>2</sup>				
	D .766	E 1.365	F 2.141	G 3.499	H 5.47
12.4	10.9	19.3	30.3	49.6	77.5
12.6	10.9	19.5	30.6	50	78.1
12.8	11	19.6	30.8	50.3	78.7
13	11.1	19.8	31	50.7	79.3
13.5	11.3	20.2	31.6	51.7	80.8
14	11.5	20.5	32.2	52.7	82.3
14.5	11.7	20.9	32.8	53.6	83.8
15	11.9	21.3	33.3	54.5	85.2
15.5	12.1	21.6	33.9	55.4	86.6
16	12.3	22	34.4	56.3	88
16.5	12.5	22.3	35	57.2	89.4
17	12.7	22.6	35.5	58	90.7
17.5	12.9	23	36	58.9	92
18	13.1	23.3	36.5	59.7	93.3
18.5	13.3	23.6	37	60.5	94.6
19	13.4	23.9	37.5	61.3	95.9
19.5	13.6	24.2	38	62.1	97.1
20	13.8	24.6	38.5	62.9	98.4
20.5	14	24.9	39	63.7	99.6
21	14.1	25.2	39.4	64.5	100.8
21.5	14.3	25.5	39.9	65.2	102
22	14.5	25.7	40.4	66	103.2
22.5	14.6	26	40.8	66.7	104.3
23	14.8	26.3	41.3	67.5	105.5
23.5	14.9	26.6	41.7	68.2	106.6
24	15.1	26.9	42.2	68.9	107.8
24.5	15.3	27.2	42.6	69.7	108.9
25	15.4	27.4	43	70.4	110
25.5	15.6	27.7	43.5	71.1	111.1
26	15.7	28	43.9	71.8	112.2
26.5	15.9	28.3	44.3	72.4	113.2
27	16	28.5	44.7	73.1	114.3
27.5	16.2	28.8	45.1	73.8	115.4
28	16.3	29	45.6	74.5	116.4
28.5	16.5	29.3	46	75.1	117.4
29	16.6	29.6	46.4	75.8	118.5
29.5	16.7	29.8	46.8	76.4	119.5
30	16.9	30.1	47.1	77.1	120.5
30.5	17	30.3	47.5	77.7	121.5
31	17.2	30.6	47.9	78.4	122.5
31.5	17.3	30.8	48.3	79	123.5
32	17.4	31.1	48.7	79.6	124.4
32.5	17.6	31.3	49.1	80.2	125.4
33	17.7	31.5	49.5	80.8	126.4
33.5	17.8	31.8	49.8	81.4	127.3
34	18	32	50.2	82.1	128.3
34.5	18.1	32.2	50.6	82.7	129.2
35	18.2	32.5	50.9	83.3	-
35.5	18.4	32.7	51.3	83.8	-
36	18.5	32.9	51.6	84.4	-
36.5	18.6	33.2	52	85	-
37	18.7	33.4	52.4	85.6	-
37.5	18.9	33.6	52.7	86.2	-
38	19	33.8	53.1	86.7	-
38.5	19.1	34.1	53.4	87.3	-
39	19.2	34.3	53.8	87.9	-
39.5	19.4	34.5	54.1	88.4	-
40	19.5	34.7	54.4	89	-
40.5	19.6	34.9	54.8	89.6	-
41	19.7	35.2	55.1	90.1	-
.1	0.02	0.05	0.06	0.11	0.17

Set Pressure Barg	Orifice Area cm <sup>2</sup>	
	D .766	E 1.365
41.5	19.9	35.4
42	20	35.6
42.5	20.1	35.8
43	20.2	36
43.5	20.3	36.2
44	20.4	36.4
44.5	20.6	36.6
45	20.7	36.8
45.5	20.8	37
46	20.9	37.2
46.5	21	37.4
47	21.1	37.6
47.5	21.2	37.8
48	21.4	38
48.5	21.5	38.2
49	21.6	38.4
49.5	21.7	38.6
50	21.8	38.8
50.5	21.9	39
51	22	39.2
51.5	22.1	39.4
52	22.2	39.6
52.5	22.3	39.8
53	22.4	40
53.5	22.5	40.2
54	22.6	40.3
54.5	22.8	40.5
55	22.9	40.7
55.5	23	40.9
56	23.1	41.1
56.5	23.2	41.3
57	23.3	41.4
57.5	23.4	41.6
58	23.5	41.8
58.5	23.6	42
59	23.7	42.2
59.5	23.8	42.3
60	23.9	42.5
60.5	24	42.7
61	24.1	42.9
61.5	24.2	43.1
62	24.3	43.2
.1	0.02	0.05

\* Pressure settings below 15 PSIG (1.034 barg) are non code.  
 \*\*For other temperatures, please use temperature correction factor.



# WATER CAPACITY CHART – MODEL 800 – CONT'D

## NON CODE

**90% rated at 25% Overpressure GPM at 60°F\*\***

**Flow Coefficient = .9 x .836 = .752**

### GPM

Set Pressure PSIG	Orifice Area in <sup>2</sup>				
	D 0.1188	E 0.2116	F 0.3318	G 0.5424	H 0.8479
5	8.5	15.1	23.7	38.8	60.6
10	12.0	21.4	33.6	54.9	85.8
15	14.7	26.2	41.1	67.2	105.0
20	17.0	30.3	47.5	77.6	121.3
25	19.0	33.8	53.1	86.7	135.6
30	20.8	37.1	58.1	95.0	148.5
35	22.5	40.0	62.8	102.6	160.4
40	24.0	42.8	67.1	109.7	171.5
45	25.5	45.4	71.2	116.4	181.9
50	26.9	47.9	75.0	122.7	191.7
55	28.2	50.2	78.7	128.6	201.1
60	29.4	52.4	82.2	134.4	210.0
65	30.6	54.6	85.6	139.9	218.6
70	31.8	56.6	88.8	145.1	226.9
75	32.9	58.6	91.9	150.2	234.8
80	34.0	60.5	94.9	155.2	242.5
85	35.0	62.4	97.8	159.9	250.0
90	36.0	64.2	100.7	164.6	257.3
95	37.0	66.0	103.4	169.1	264.3
100	38.0	67.7	106.1	173.5	271.2
105	38.9	69.3	108.7	177.8	277.9
110	39.8	71.0	111.3	181.9	284.4
115	40.7	72.6	113.8	186.0	290.8
120	41.6	74.1	116.2	190.0	297.1
125	42.5	75.7	118.6	193.9	303.2
130	43.3	77.2	121.0	197.8	309.2
135	44.1	78.6	123.3	201.6	315.1
140	45.0	80.1	125.6	205.2	320.9
145	45.8	81.5	127.8	208.9	326.5
150	46.5	82.9	130.0	212.5	332.1
155	47.3	84.3	132.1	216.0	337.6
160	48.1	85.6	134.2	219.4	343.0
165	48.8	86.9	136.3	222.8	348.3
170	49.5	88.2	138.4	226.2	353.6
175	50.3	89.5	140.4	229.5	358.7
180	51.0	90.8	142.4	232.7	363.8
185	51.7	92.0	144.3	235.9	368.8
190	52.4	93.3	146.3	239.1	373.8
195	53.1	94.5	148.2	242.2	378.7
200	53.7	95.7	150.1	245.3	383.5
205	54.4	96.9	151.9	248.4	388.3
210	55.1	98.1	153.8	251.4	393.0
215	55.7	99.2	155.6	254.4	397.6
220	56.4	100.4	157.4	257.3	402.2
225	57.0	101.5	159.2	260.2	406.8
230	57.6	102.6	160.9	263.1	411.3
235	58.2	103.7	162.7	265.9	415.7
240	58.9	104.8	164.4	268.7	420.1
245	59.5	105.9	166.1	271.5	424.4
250	60.1	107.0	167.8	274.3	428.8
255	60.7	108.1	169.5	277.0	433.0
260	61.3	109.1	171.1	279.7	437.2
265	61.8	110.2	172.7	282.4	441.4
270	62.4	111.2	174.4	285.0	445.6
275	63.0	112.2	176.0	287.7	449.7
280	63.6	113.2	177.6	290.3	453.8
285	64.1	114.2	179.1	292.8	457.8
290	64.7	115.2	180.7	295.4	461.8
295	65.3	116.2	182.3	297.9	465.8
300	65.8	117.2	183.8	300.5	469.7
1.0	0.10	0.20	0.30	0.50	0.80

Set Pressure PSIG	Orifice Area in <sup>2</sup>				
	D 0.1188	E 0.2116	F 0.3318	G 0.5424	H 0.8479
305	66.4	118.2	185.3	302.9	473.6
310	66.9	119.2	186.8	305.4	477.4
315	67.4	120.1	188.3	307.9	481.3
320	68.0	121.1	189.8	310.3	485.1
325	68.5	122.0	191.3	312.7	488.9
330	69.0	122.9	192.8	315.1	492.6
335	69.5	123.9	194.2	317.5	496.3
340	70.1	124.8	195.7	319.9	500.0
345	70.6	125.7	197.1	322.2	503.7
350	71.1	126.6	198.5	324.5	507.3
355	71.6	127.5	199.9	326.8	510.9
360	72.1	128.4	201.3	329.1	514.5
365	72.6	129.3	202.7	331.4	518.1
370	73.1	130.2	204.1	333.7	521.6
375	73.6	131.0	205.5	335.9	525.1
380	74.1	131.9	206.9	338.1	528.6
385	74.5	132.8	208.2	340.4	532.1
390	75.0	133.6	209.6	342.6	535.5
395	75.5	134.5	210.9	344.8	538.9
400	76.0	135.3	212.2	346.9	542.3
405	76.5	136.2	213.6	349.1	545.7
410	76.9	137.0	214.9	351.2	549.1
415	77.4	137.9	216.2	353.4	552.4
420	77.9	138.7	217.5	355.5	555.7
425	78.3	139.5	218.8	357.6	559.0
430	78.8	140.3	220.0	359.7	562.3
435	79.2	141.1	221.3	361.8	565.6
440	79.7	142.0	222.6	363.9	568.8
445	80.1	142.8	223.8	365.9	572.0
450	80.6	143.6	225.1	368.0	575.2
455	81.0	144.4	226.3	370.0	578.4
460	81.5	145.1	227.6	372.0	581.6
465	81.9	145.9	228.8	374.1	584.7
470	82.4	146.7	230.1	376.1	587.9
475	82.8	147.5	231.3	378.1	591.0
480	83.2	148.3	232.5	380.0	594.1
485	83.7	149.0	233.7	382.0	597.2
490	84.1	149.8	234.9	384.0	600.3
495	84.5	150.6	236.1	385.9	603.3
500	85.0	151.3	237.3	387.9	606.4
505	85.4	152.1	238.5	389.8	-
510	85.8	152.8	239.6	391.7	-
515	86.2	153.6	240.8	393.7	-
520	86.6	154.3	242.0	395.6	-
525	87.1	155.1	243.1	397.5	-
530	87.5	155.8	244.3	399.4	-
535	87.9	156.5	245.4	401.2	-
540	88.3	157.3	246.6	403.1	-
545	88.7	158.0	247.7	405.0	-
550	89.1	158.7	248.9	406.8	-
555	89.5	159.4	250.0	408.7	-
560	89.9	160.1	251.1	410.5	-
565	90.3	160.9	252.2	412.3	-
570	90.7	161.6	253.3	414.1	-
575	91.1	162.3	254.5	416.0	-
580	91.5	163.0	255.6	417.8	-
585	91.9	163.7	256.7	419.6	-
590	86.6	154.2	241.8	395.3	-
595	86.9	154.9	242.8	396.9	-
600	87.3	155.5	243.8	398.6	-
1.0	0.10	0.20	0.28	0.48	0.74

Set Pressure PSIG	Orifice Area in <sup>2</sup>	
	D 0.1188	E 0.2116
605	93.5	166.5
610	93.8	167.1
615	94.2	167.8
620	94.6	168.5
625	95.0	169.2
630	95.4	169.9
635	95.7	170.5
640	96.1	171.2
645	96.5	171.9
650	96.9	172.5
655	97.2	173.2
660	97.6	173.9
665	98.0	174.5
670	98.3	175.2
675	98.7	175.8
680	99.1	176.5
685	99.4	177.1
690	99.8	177.8
695	100.2	178.4
700	100.5	179.0
705	100.9	179.7
710	101.2	180.3
715	101.6	181.0
720	101.9	181.6
725	102.3	182.2
730	102.7	182.8
735	103.0	183.5
740	103.4	184.1
745	103.7	184.7
750	104.1	185.3
755	104.4	185.9
760	104.7	186.6
765	105.1	187.2
770	105.4	187.8
775	105.8	188.4
780	106.1	189.0
785	106.5	189.6
790	106.8	190.2
795	107.1	190.8
800	107.5	191.4
805	107.8	192.0
810	108.1	192.6
815	108.5	193.2
820	108.8	193.8
825	109.1	194.4
830	109.5	195.0
835	109.8	195.5
840	110.1	196.1
845	110.4	196.7
850	110.8	197.3
855	111.1	197.9
860	111.4	198.5
865	111.7	199.0
870	112.1	199.6
875	112.4	200.2
880	112.7	200.7
885	113.0	201.3
890	113.3	201.8
895	113.7	202.5
900	114.0	203.0
1.0	0.10	0.20

\*\*For other temperatures, please use temperature correction factor.



# WATER CAPACITY CHART – MODEL 800 – CONT'D.

## NON CODE

90% rated at 25% Overpressure M<sup>3</sup>/HR at 15.6°C\*\*

Flow Coefficient = .9 x .836 = .752

M<sup>3</sup>/HR

Set Pressure Barg	Orifice Area cm <sup>2</sup>				
	D .766	E 1.365	F 2.141	G 3.499	H 5.47
0.4	2.3	4.1	6.4	10.5	16.3
0.6	2.6	4.7	7.4	12.1	18.8
0.8	2.9	5.3	8.2	13.5	21
1	3.3	5.9	9.2	15	23.5
1.2	3.6	6.4	10.1	16.4	25.7
1.4	3.9	6.9	10.9	17.7	27.7
1.6	4.2	7.4	11.6	19	29.7
1.8	4.4	7.9	12.3	20.1	31.5
2	4.6	8.3	13	21.2	33.2
2.2	4.9	8.7	13.6	22.2	34.8
2.4	5.1	9.1	14.2	23.2	36.3
2.6	5.3	9.4	14.8	24.2	37.8
2.8	5.5	9.8	15.4	25.1	39.2
3	5.7	10.1	15.9	26	40.6
3.2	5.9	10.5	16.4	26.8	41.9
3.4	6.1	10.8	16.9	27.7	43.2
3.6	6.2	11.1	17.4	28.5	44.5
3.8	6.4	11.4	17.9	29.2	45.7
4	6.6	11.7	18.4	30	46.9
4.2	6.7	12	18.8	30.7	48.1
4.4	6.9	12.3	19.2	31.5	49.2
4.6	7	12.6	19.7	32.2	50.3
4.8	7.2	12.8	20.1	32.9	51.4
5	7.3	13.1	20.5	33.5	52.4
5.2	7.5	13.3	20.9	34.2	53.5
5.4	7.6	13.6	21.3	34.9	54.5
5.6	7.8	13.8	21.7	35.5	55.5
5.8	7.9	14.1	22.1	36.1	56.5
6	8	14.3	22.5	36.7	57.4
6.2	8.2	14.6	22.8	37.4	58.4
6.4	8.3	14.8	23.2	37.9	59.3
6.6	8.4	15	23.6	38.5	60.2
6.8	8.6	15.3	23.9	39.1	61.2
7	8.7	15.5	24.3	39.7	62
7.2	8.8	15.7	24.6	40.3	62.9
7.4	8.9	15.9	25	40.8	63.8
7.6	9.1	16.1	25.3	41.4	64.6
7.8	9.2	16.3	25.6	41.9	65.5
8	9.3	16.6	26	42.4	66.3
8.2	9.4	16.8	26.3	43	67.2
8.4	9.5	17	26.6	43.5	68
8.6	9.6	17.2	26.9	44	68.8
8.8	9.7	17.4	27.2	44.5	69.6
9	9.9	17.6	27.5	45	70.4
9.2	10	17.8	27.8	45.5	71.1
9.4	10.1	17.9	28.1	46	71.9
9.6	10.2	18.1	28.4	46.5	72.7
9.8	10.3	18.3	28.7	47	73.4
10	10.4	18.5	29	47.4	74.2
10.2	10.5	18.7	29.3	47.9	74.9
10.4	10.6	18.9	29.6	48.4	75.6
10.6	10.7	19.1	29.9	48.8	76.3
10.8	10.8	19.2	30.2	49.3	77.1
11	10.9	19.4	30.4	49.8	77.8
11.2	11	19.6	30.7	50.2	78.5
11.4	11.1	19.8	31	50.6	79.2
11.6	11.2	19.9	31.3	51.1	79.9
11.8	11.3	20.1	31.5	51.5	80.6
12	11.4	20.3	31.8	52	81.2
12.2	11.5	20.4	32.1	52.4	81.9
.1	0.02	0.05	0.07	0.11	0.18

Set Pressure Barg	Orifice Area cm <sup>2</sup>				
	D .766	E 1.365	F 2.141	G 3.499	H 5.47
12.4	11.6	20.6	32.3	52.8	82.6
12.6	11.7	20.8	32.6	53.2	83.2
12.8	11.8	20.9	32.8	53.7	83.9
13	11.8	21.1	33.1	54.1	84.6
13.5	12.1	21.5	33.7	55.1	86.2
14	12.3	21.9	34.3	56.1	87.7
14.5	12.5	22.3	34.9	57.1	89.3
15	12.7	22.7	35.5	58.1	90.8
15.5	12.9	23	36.1	59.1	92.3
16	13.1	23.4	36.7	60	93.8
16.5	13.3	23.8	37.3	60.9	95.3
17	13.5	24.1	37.8	61.9	96.7
17.5	13.7	24.5	38.4	62.8	98.1
18	13.9	24.8	38.9	63.6	99.5
18.5	14.1	25.2	39.5	64.5	100.9
19	14.3	25.5	40	65.4	102.2
19.5	14.5	25.8	40.5	66.2	103.6
20	14.7	26.2	41	67.1	104.9
20.5	14.9	26.5	41.5	67.9	106.2
21	15.1	26.8	42.1	68.7	107.5
21.5	15.2	27.1	42.5	69.6	108.7
22	15.4	27.4	43	70.4	110
22.5	15.6	27.8	43.5	71.2	111.2
23	15.8	28.1	44	71.9	112.5
23.5	15.9	28.4	44.5	72.7	113.7
24	16.1	28.7	45	73.5	114.9
24.5	16.3	29	45.4	74.3	116.1
25	16.4	29.3	45.9	75	117.3
25.5	16.6	29.6	46.3	75.8	118.4
26	16.8	29.8	46.8	76.5	119.6
26.5	16.9	30.1	47.2	77.2	120.7
27	17.1	30.4	47.7	77.9	121.8
27.5	17.2	30.7	48.1	78.7	123
28	17.4	31	48.6	79.4	124.1
28.5	17.5	31.2	49	80.1	125.2
29	17.7	31.5	49.4	80.8	126.3
29.5	17.8	31.8	49.8	81.5	127.4
30	18	32.1	50.3	82.2	128.4
30.5	18.1	32.3	50.7	82.8	129.5
31	18.3	32.6	51.1	83.5	130.6
31.5	18.4	32.8	51.5	84.2	131.6
32	18.6	33.1	51.9	84.9	132.7
32.5	18.7	33.4	52.3	85.5	133.7
33	18.9	33.6	52.7	86.2	134.7
33.5	19	33.9	53.1	86.8	135.7
34	19.2	34.1	53.5	87.5	136.7
34.5	19.3	34.4	53.9	88.1	137.7
35	19.4	34.6	54.3	88.7	-
35.5	19.6	34.9	54.7	89.4	-
36	19.7	35.1	55.1	90	-
36.5	19.9	35.4	55.4	90.6	-
37	20	35.6	55.8	91.2	-
37.5	20.1	35.8	56.2	91.9	-
38	20.3	36.1	56.6	92.5	-
38.5	20.4	36.3	56.9	93.1	-
39	20.5	36.5	57.3	93.7	-
39.5	20.6	36.8	57.7	94.3	-
40	20.8	37	58	94.9	-
40.5	20.9	37.2	58.4	95.5	-
41	21	37.5	58.8	96.1	-
.1	0.02	0.05	0.07	0.11	0.18

Set Pressure Barg	Orifice Area cm <sup>2</sup>	
	D .766	E 1.365
41.5	21.2	37.7
42	21.3	37.9
42.5	21.4	38.2
43	21.5	38.4
43.5	21.7	38.6
44	21.8	38.8
44.5	21.9	39
45	22	39.3
45.5	22.2	39.5
46	22.3	39.7
46.5	22.4	39.9
47	22.5	40.1
47.5	22.6	40.3
48	22.8	40.5
48.5	22.9	40.8
49	23	41
49.5	23.1	41.2
50	23.2	41.4
50.5	23.3	41.6
51	23.5	41.8
51.5	23.6	42
52	23.7	42.2
52.5	23.8	42.4
53	23.9	42.6
53.5	24	42.8
54	24.1	43
54.5	24.3	43.2
55	24.4	43.4
55.5	24.5	43.6
56	24.6	43.8
56.5	24.7	44
57	24.8	44.2
57.5	24.9	44.4
58	25	44.6
58.5	25.1	44.8
59	25.2	45
59.5	25.3	45.1
60	25.5	45.3
60.5	25.6	45.5
61	25.7	45.7
61.5	25.8	45.9
62	25.9	46.1
.1	0.02	0.05

\*\*For other temperatures, please use temperature correction factor.



# VACUUM CAPACITY CHART – MODEL 800

**NON CODE – Plain or Packed Cap**  
**90% rated SCFM (NM<sup>3</sup>/HR) at 60°F (15.6°C)\*\***  
**Flow Coefficient = .9 x .975 = .878**

**SCFM**

Set Pressure in.HG	Orifice Area in <sup>2</sup>				
	D	E	F	G	H
	0.1188	0.2116	0.3318	0.5424	0.8479
10	27	48	76	124	194
11	28	50	78	127	199
12	28	51	80	130	204
13	29	52	82	133	208
14	29	53	83	135	211
15	30	53	84	137	214
16	30	54	85	138	216
17	30	54	85	139	218
18	30	55	86	140	219
19	31	55	86	140	220
20	31	55	86	141	220
21	31	55	86	141	220
22	31	55	86	141	220
23	31	55	86	141	220
24	31	55	86	141	220
25	31	55	86	141	220
26	31	55	86	141	220
27	31	55	86	141	220
28	31	55	86	141	220
29	31	55	86	141	220
30	31	55	86	141	220

**Nm<sup>3</sup>/HR**

Set Pressure mmHG	Orifice Area cm <sup>2</sup>				
	D	E	F	G	H
	.766	1.365	2.141	3.499	5.47
254.0	46	82	129	211	330
279.4	48	85	133	216	338
304.8	48	87	136	221	347
330.2	49	88	139	226	353
355.6	49	90	141	229	358
381.0	51	90	143	233	364
406.4	51	92	144	234	367
431.8	51	92	144	236	370
457.2	51	93	146	238	372
482.6	53	93	146	238	374
508.0	53	93	146	240	374
533.4	53	93	146	240	374
558.8	53	93	146	240	374
584.2	53	93	146	240	374
609.6	53	93	146	240	374
635.0	53	93	146	240	374
660.4	53	93	146	240	374
685.8	53	93	146	240	374
711.2	53	93	146	240	374
736.6	53	93	146	240	374
762.0	53	93	146	240	374

\*\* For other temperatures, please use temperature correction factor.