

FIGURE 15 SERIES

SIZES ¾" - 3"

PRESSURES to 15 PSIG at 400°F



FIGURE 15LC SAFETY VALVE

- Air & Non-hazardous Service
- Low Cost
- High Capacity
- Cast Iron or Aluminum Body
- Dependable
- Tight Shutoff
- Sharp Popping & Closing Action
- High Degree of Repeatability
- Unitized Body

OPTIONS

- Stainless Trim
- Set Pressures 15 to 60 psi (Consult Factory)

MODELS

- 015C - Cast Iron Body, Bronze Seats, Pull Ring
- 015A - Cast Iron Body, Bronze Seats, Sealed Cap
- 15LC - Aluminum Body on 015C (2 x 2½ only)
- 15LA - Aluminum Body on 015A (2 x 2½ only)

APPLICATION DATA

- Bulk Hauling Railroad and Truck Tank Cars
- High Volume Blowers
- Compressors
- Dryers
- Pneumatic Equipment
- Tanks

VALVE RATINGS

Model	Pressure PSIG (bar)	Temperature °F (°C)
All	5 to 15 (.3 to 1)	-20 to 400 (-29 to 204)

APPLICABLE CODES

- ASME Section VIII "UV" for Air (2" Figure 15C & 15LC only)
- Canadian Registration #OG0591.9C — 015C, 015LC
#OH0591.9C — 015A, 015LA

Sizing Guidelines

Testing Specifications

Installation/Maintenance

ORDERING CODE

MODEL NUMBER (Must be 4 Digits)	ORIFICE	INLET SIZE	CONNECTIONS	—	SET PRESSURE (Must be 3 Digits)
example: 015C	Z	K	A	—	015
015C - Cast Iron Body, Brz Seats, Pull Ring	Z	D - ¾"	A - MPT x FPT		Set Pressure
015A - Cast Iron Body, Brz Seats, Sealed Cap		E - 1"			LAS - Loosely Assembled†
15LC - Aluminum Body on 015C (2 x 2½ only)		F - 1¼"			
15LA - Aluminum Body on 015A (2 x 2½ only)		G - 1½"			
		H - 2"			
		J - 2½"			
		K - 3"			

†Spence Certified Assemblers Only

FIGURE 15 SERIES

SPECIFICATION

The valve inlet and outlet shall be one integral casting assuring proper alignment of disc, seat and spindle for smooth action. The valve shall maintain a high degree of repeatability. The valve shall be top guided by a disc guide fitted into the body. The valve shall have a non-adjustable blowdown.

MATERIALS OF CONSTRUCTION

Ref	Part Name	Material
1	Pull Ring	SST
3	Compression Screw	Stl. plated CI ASTM A108/A126
4	Seal Wire	SST
5	Seal	Lead
6	Lock Screw	Brass ASTM B16
7	Drive Screw	SST
8	Nameplate	SST
9	Wave Washer	Plated Steel
10	Spring	Plated Steel
11	Disc Guide	Brass/Bronze ASTM B135/B505
12	Spindle Pin	Plated Steel
13	Spring Washer	Plated Steel
14	Spindle	Steel ASTM A108
15	Disc	Brass/Bronze ASTM B16/B62
16	Seat	Brass/Bronze ASTM B16/B505
17	Body	Cast Iron ASTM A126
18	Sealant	Sealant
19	Bushing 015A/15LA	Brass ASTM B16

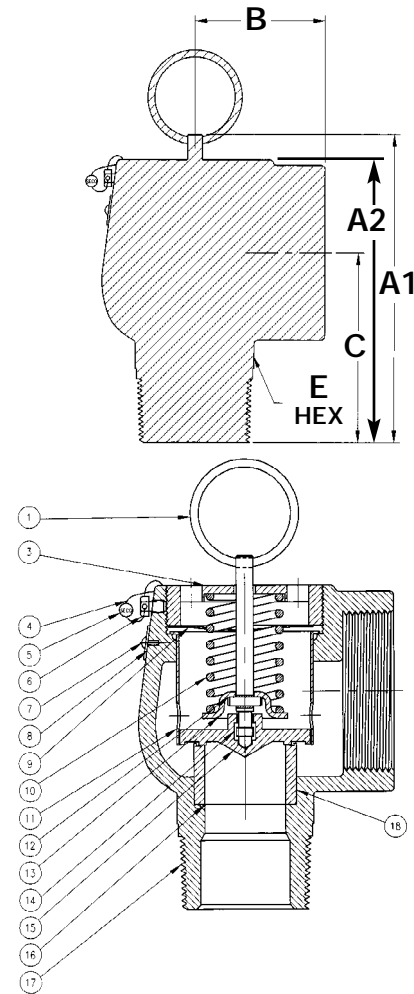

DIMENSIONS inches (mm) AND WEIGHTS pounds (kg)

Model	Inlet	Orifice	Outlet	A1	A2	B	C	E Hex	Weight
****ZDA	3/4 (20)	Z	1 (25)	3 5/16 (76)	3 (76)	1 1/2 (38)	2 3/16 (56)	1 1/4 (32)	1 (.4)
****ZEA	1 (25)	Z	1 1/4 (32)	4 (95)	3 3/4 (95)	2 (51)	2 5/8 (67)	1 1/2 (38)	2 (.9)
****ZFA	1 1/4 (32)	Z	1 1/2 (40)	5 (108)	4 1/4 (108)	2 1/2 (54)	3 (76)	1 5/8 (48)	3 (1.4)
****ZGA	1 1/2 (40)	Z	2 (50)	5 1/2 (117)	4 5/8 (117)	2 3/8 (56)	3 3/8 (81)	2 (51)	4 (1.8)
****ZHA	2 (50)	Z	2 1/2 (65)	6 11/16 (156)	6 5/8 (156)	2 7/8 (73)	4 (102)	3 (76)	8 (3.6)
****ZJA	2 1/2 (65)	Z	2 1/2 (65)	8 3/8 (194)	7 7/8 (194)	3 3/8 (95)	4 3/8 (111)	3 3/4 (83)	14 (6.3)
****ZKA	3 (80)	Z	3 (80)	9 1/2 (229)	9 (229)	3 7/8 (98)	5 1/8 (130)	4 (102)	22 (10)

**** Use appropriate Model Number.

AIR CAPACITY CHART – MODELS 015C, 015A, 15LC, 15LA

**ASME Section VIII "UV" 90% rated at 3 PSI Overpressure SCFM (M³/HR)

SCFM

Set Pressure PSIG	Valve & Orifice Area, in ²						
	3/4 Z 1	1 Z 1 1/4	1 1/4 Z 1 1/2	1 1/2 Z 2	2 Z 2 1/2	2 1/2 Z 2 1/2	3 Z 3
0.276	0.276	0.49	0.765	1.107	1.961	3.063	4.43
5*	82	145	226	328	579	906	1311
10*	100	177	276	400	706	1105	1599
15	118	209	326	472	834	1305	1888
1	3.6	6.4	10.0	14.4	25.5	39.9	57.7

M³/HR

Set Pressure Barg	Valve & Orifice Area cm ²						
	20 Z 25	25 Z 32	32 Z 40	40 Z 50	50 Z 65	65 Z 65	80 Z 80
1.78	1.78	3.16	4.94	7.14	12.65	19.76	25.58
0.4*	144	255	398	576	1018	1593	2305
0.7*	171	302	472	683	1207	1888	2732
1.0*	197	350	545	790	1395	2183	3159
0.1	9	16	25	36	63	98	142.1

* Pressure settings below 15 PSIG (1.034 barg) are non code.

**Only 2" size is ASME Certified.