

N125 SERIES THERMOSTATIC STEAM TRAPS

**Pressures to 125 PSIG (8.75 barg)
Temperatures to 400°F (204°C)**

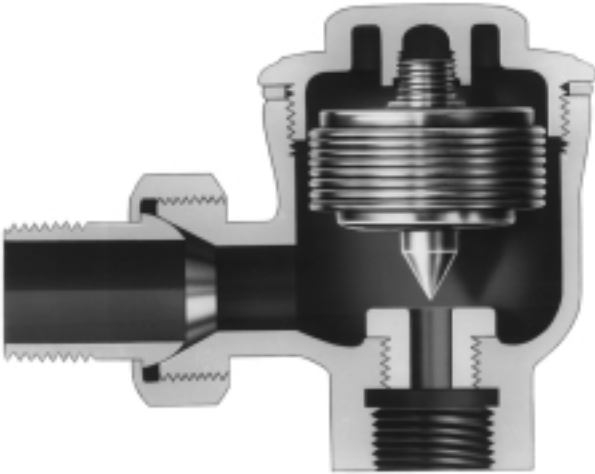

Applications

- Steam Tracing
- Drip Legs
- Automatic Air Vents
- Sterilizers
- Cooking Kettles
- Water Heaters
- Laundry Equipment
- Radiators
- Process Equipment
- Air Handlers

Options *See page 8*

- ST - Sterilizer Trim (with Monel Bellows only)
- SLR - SLR Orifice
- S - Internal Stainless Strainer
- ISO - ISO Filled Actuator
- FC - Fail Closed
- FO - Fail Open

Canadian Registration # 0E0591.9

Superior Performance — Hardened valve and seats are lapped in matched sets, providing tight shutoff and long service life.

Improved Energy Savings — Maximum elimination of air and non-condensibles—trap closes at saturated steam temperature.

Temperature Sensitive Actuators — One moving part. Monel actuator for caustic corrosion resistance. Choose Stainless Steel, fail open, welded actuator for maximum corrosion, thermal and hydraulic shock resistance.

Freeze Proof — Threaded male union horizontal inlet and vertical outlet—self draining.

In-line Maintenance — Threaded cover for one step removal, inspection and service without breaking pipe connections.

Air Vent — Efficient steam service air vent when equipped with ISO Bellows and installed in air vent location.

Guaranteed — Traps guaranteed against defects in materials or workmanship for 3 years.

Models

- **N125-FC**—Standard capacity, fail closed
- **N125-FO**—Standard capacity, fail open
- **N125L-FC**—Low capacity, fail closed
- **N125L-FO**—Low capacity, fail open
- **N125HC-FC**—High capacity, fail closed
- **N125HC-FO**—High capacity, fail open
- **N125ST-FC**—Standard capacity w/sterilizer seat, fail closed

Operating Principle

Thermal actuator is filled at its free length with a liquid having a lower boiling point than water. On start-up, valve is normally open. When steam enters trap, thermal actuator fill vaporizes to a pressure higher than line pressure. This forces valve into seat orifice to prevent any further flow. As condensate collects, it takes heat from thermal actuator, lowering internal

pressure. Line pressure will then compress thermal actuator to open valve and discharge condensate. Valve opening automatically adjusts to load conditions from minimum on very light loads to full lift at maximum load. Restricted orifice in N125L (small opening at bottom of valve seat) prevents trap from discharging continuously on light loads.

N125 SERIES THERMOSTATIC STEAM TRAPS

Typical Specification

Steam trap shall be of balanced pressure design with stainless steel welded actuator capable of discharging condensate within 10°F of saturated temperature. Where greater sensitivity is required, SLR orifice and Sterilizer trim will be available to allow condensate evacuation at or near saturated temperatures. Where subcooling of condensate is desired alternate thermostatic actuator will be available to allow condensate evacuation at or near 40°F below saturated temperatures. Thermostatic actuator shall employ a conical valve lapped in matched sets with the seat ring assuring tight shut off. A minimum of three orifice sizes shall be available allowing for custom capacity sizing. Trap shall be bronze bodied suitable for pressures through 125 psig and available in 3/8" through 3/4" NPT connections.

Maximum Operating Conditions

PMO: Max. Operating Pressure 125 psig (8.75 barg)
 TMO: Max. Operating Temperature 400°F (204°C)
 PMA: Max. Allowable Pressure 125 psig (8.75 barg)
 TMA: Max. Allowable Temperature 400°F (204°F)

Materials of Construction

Body & Cover: ASTM B283 C37700
 Actuator: Welded Stainless Steel
 Cover Gasket: Copper Jacketed
 Valve & Seat: Hardened 416 Stainless Steel

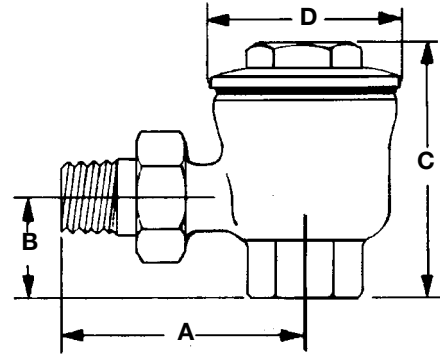

Connections: 3/8"-3/4" NPT

Dimensions					
Size	Inch (mm)				Weight lb (kg)
	A	B	C	D	
3/8, 1/2"	2 ³ / ₄ (70)	1 ¹ / ₈ (29)	2 ⁷ / ₈ (73)	2 ⁵ / ₃₂ (54)	1.5 (.68)
3/4"	3 ³ / ₁₆ (81)	1 ⁹ / ₁₆ (40)	3 (76)	2 ⁵ / ₃₂ (54)	1.8 (.82)

Maximum Capacity—lbs/hr 10°F Below Saturation (Kg/hr 5°C Below Saturation)							
Trap	Orifice Inch (mm)	Differential PSIG (barg)					
		5 (0.34)	10 (0.7)	20 (1.4)	50 (3.5)	100 (6.9)	125 (8.6)
N125L	1/8 (3)	216 (98)	265 (120)	375 (170)	592 (269)	778 (354)	838 (381)
N125 N125ST	1/4 (6)	550 (249)	825 (374)	1210 (549)	1975 (896)	2825 (1281)	3140 (1424)
N125HC	5/16 (8)	860 (390)	1220 (554)	1725 (783)	2725 (1237)	3575 (1623)	3850 (1748)

Nicholson recommends ISO filled Actuator for superheated steam.