



MAX-FLO SUPER HIGH CAPACITY FLOAT & THERMOSTATIC STEAM TRAPS

Pressures to 175 PSIG (12.1 barg)
Temperatures to 377°F (260°C)

- High Capacities
- Rugged cast iron body and cover
- Stainless steel thermostatic element eliminates air binding
- Stainless steel float and lever mechanism
- Below condensate level seat design prevents steam leakage
- Resistant to water hammer and corrosion
- In-Line repairable

APPLICATIONS

- Very High Condensate Loads
- Continuous Drainage With High Air Venting Capacity Requirements
- Industrial And Commercial Applications
- Absorption Systems
- Air Handling Coils
- Heat Exchangers
- Dryers Evaporators
- Hot water Generators
- Rendering Machines
- Steam Process Equipment
- Air Make-up Coils
- Unit Heaters And Cooking Kettles

MODELS

- HC-15 - Steam pressures to 15 PSIG
- HC-30 - Steam pressures to 30 PSIG
- HC-75 - Steam pressures to 75 PSIG
- HC-125 - Steam pressures to 125 PSIG
- HC-175 - Steam pressures to 175 PSIG

Installation Tip: Always install STV Test & Block Valve as part of trap station

Installation Tip: Add Uniflex Pipe Coupling for ease of maintenance

OPERATION

During startup, air and non-condensable gases enter the trap and are automatically vented through an accurate balanced pressure internal thermostatic air vent. As condensate enters the trap, the float and lever mechanism is raised, lifting the valve off

the seat, discharging the condensate. Condensate will continue to be discharged at the same rate at which it is entering. Any air or non-condensable gas that may accumulate will be continually and efficiently passed by the thermostatic air vent.

MAX-FLO SUPER HIGH CAPACITY FLOAT & THERMOSTATIC STEAM TRAPS

SPECIFICATION

Steam trap shall be of float and thermostatic design. Float shall actuate the valve via a hinged lever and linkage. Air vent shall be of balanced pressure design with stainless steel welded encapsulated bellows capable of discharging air and noncondensable gases continuously. Trap shall be cast iron bodied suitable for pressures to 175 PSI and shall be a _____ NPT connection.

MAXIMUM OPERATING CONDITIONS

PMO: Max. Operating Pressure see orifice selection
 TMO: Max. Operating Temperature saturated at pressure
 PMA: Max. Allowable Pressure 175 PSIG (12.1 barg)
 PMA: Max. Allowable Pressure 377°F (192°C)

MATERIALS OF CONSTRUCTION

Body & CoverCast Iron 30,000 psi tensile
 Valve Pin and SeatStainless Steel (Hardened)
 FloatStainless Steel
 Lever AssemblyStainless Steel
 Thermostatic Air VentStainless Steel Cage
 & Thermal Element
 Cover BoltsGrade 5
 BaffleStainless Steel (2-1/2 (65mm) units only)

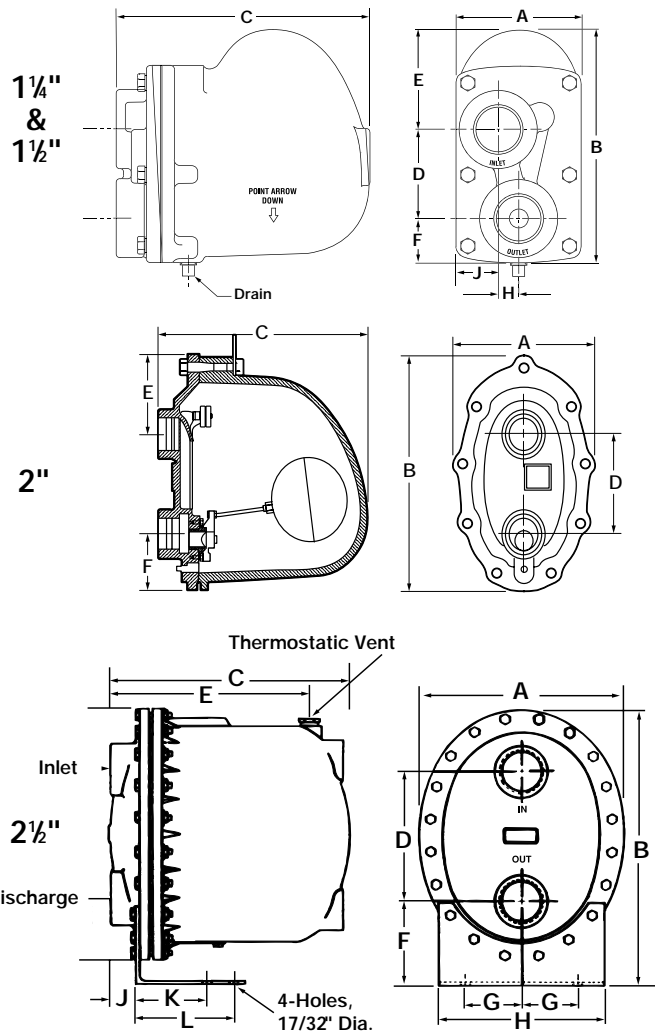

| Dimensions | | | | | | | | | | | | | |
|------------|----------------------|--------------|--------------|--------------|-------------|--------------|-------------|------------|--------------|------------|-------------|------------|--------------------|
| MODEL | NPT Size in. (mm) | A | B | C | D | E | F | G | H | J | K | L | Weight lbs (kg) |
| HC-175 | 1½ & 1½ (32 & 40) | 4½ (108) | 8¾ (211) | 8¾ (217) | 3 (76) | 3¾ (86) | 2 (51) | — | 4¾ (17.8) | 1¾ (35) | — | — | 18 (8) |
| ALL | 2 (50) | 10 (254) | 15 (381) | 15½ (394) | 6¾ (168) | 4¾ (121) | 3½ (89) | — | — | — | — | — | 108 (49) |
| ALL | 2½ (65) | 14½ (368) | 20¾ (514) | 17¾ (441) | 9½ (241) | 14¼ (379) | 6¾ (159) | 5 (127) | 12 (305) | 1¾ (41) | 4¾ (114) | 7 (178) | 175 (79) |

| Maximum Capacity-lbs/hr | | | | | | | | | | | | | | | | | | | |
|-------------------------|-------------------|----------------------------|----------------|-------------|-------------|-------------|--------------|-------------|-------------|--------------|-------------|-------------|-------------|-------------|-------------|--------------|--------------|---------------|---------------|
| Trap | Orifice Max ΔP | Differential - PSIG (barg) | | | | | | | | | | | | | | | | | |
| | | 1/4 (0.017) | 1/2 (0.035) | 1 (0.07) | 2 (0.14) | 5 (0.35) | 10 (0.69) | 15 (1.0) | 20 (1.4) | 25 (1.69) | 30 (2.1) | 40 (2.8) | 50 (3.5) | 60 (4.2) | 75 (5.2) | 100 (6.9) | 125 (8.6) | 150 (10.4) | 175 (12.1) |
| HC-15, 2" | .970 | 6500 | 8000 | 9500 | 10800 | 15500 | 20900 | 24000 | | | | | | | | | | | |
| HC-15, 2½" | 1.875 | 17000 | 20000 | 27000 | 36000 | 46000 | 55000 | 60000 | | | | | | | | | | | |
| HC-30, 2" | .876 | 3400 | 4600 | 6400 | 8400 | 12500 | 16900 | 19000 | 21500 | 23590 | 24000 | | | | | | | | |
| HC-30, 2½" | 1.624 | 14000 | 17000 | 20900 | 25500 | 33200 | 40500 | 45500 | 49400 | 52700 | 55600 | | | | | | | | |
| HC-75, 2" | .858 | 2550 | 3150 | 4300 | 5450 | 7600 | 10400 | 11400 | 12500 | 13500 | 14250 | 15600 | 17150 | 18600 | 20500 | | | | |
| HC-75, 2½" | 1.031 | 5900 | 7700 | 10000 | 13000 | 18600 | 24200 | 28300 | 31600 | 34400 | 36800 | 41100 | 44800 | 48040 | 52300 | | | | |
| HC-125, 2" | .448 | 2300 | 2800 | 3450 | 4200 | 5450 | 6600 | 7450 | 8050 | 8600 | 8950 | 10350 | 11950 | 13400 | 15600 | 18850 | 21800 | | |
| HC-125, 2½" | .797 | 4000 | 5300 | 6900 | 9100 | 13000 | 17100 | 20000 | 22400 | 24500 | 26300 | 29400 | 32100 | 34650 | 37600 | 42100 | 46000 | | |
| HC-175, 1½" | .210 | 260 | 350 | 480 | 640 | 940 | 1190 | 1450 | 1560 | 1670 | 1750 | 1910 | 2040 | 2100 | 2300 | 2500 | 2900 | 3140 | 3240 |
| HC-175, 1½" | .210 | 260 | 350 | 480 | 640 | 940 | 119 | 1450 | 1560 | 1670 | 1750 | 1910 | 2040 | 2100 | 2300 | 2500 | 2900 | 3140 | 3240 |
| HC-175, 2" | .375 | 2100 | 2600 | 3000 | 3500 | 4400 | 4900 | 5350 | 5800 | 6250 | 6700 | 7600 | 8600 | 9550 | 11000 | 13000 | 14750 | 16500 | 18000 |
| HC-175, 2½" | .688 | 2460 | 3350 | 4600 | 6200 | 9400 | 12800 | 15400 | 17500 | 19300 | 21000 | 23800 | 26300 | 28060 | 31600 | 35900 | 39700 | 43100 | 46200 |

For Kg/Hr Multiply by .454